

Inductive sensor
For rotary actuators
NI4-DSC26-2Y1X2-H1140

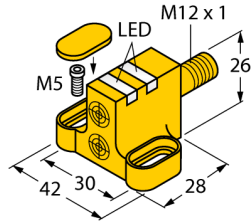

- ATEX category II 2 G, Ex zone 1
- ATEX category II 1 D, Ex zone 20
- SIL2 (Low Demand Mode) acc. to IEC 61508, PL c acc. to ISO 13849-1 at HFT0
- SIL3 (All Demand Mode) acc. to IEC 61508, PL e acc. to ISO 13849-1 with redundant configuration HFT1
- Rectangular, housing DSC26
- Plastic, PP
- Two outputs for monitoring the position of rotary actuators
- Mounting on all standard actuators
- DC 2-wire, nom. 8.2 VDC
- 2 outputs acc. to DIN EN 60947-5-6 (NAMUR)
- M12 x 1 male connector

Wiring Diagram

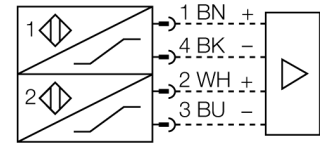

Functional principle

Inductive sensors detect metal objects contactless and wear-free. Dual sensors are especially designed for position detection in rotary actuators. They combine the reliability of non-contact inductive sensors with the flexibility of a modular housing system.

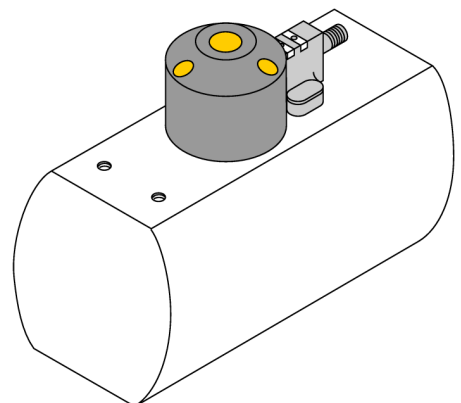

Type designation	NI4-DSC26-2Y1X2-H1140
Ident-No.	1051001
Rated switching distance S_n	4 mm
Mounting conditions	Non-flush
Correction factors	St37 = 1; Al = 0.3; stainless steel = 0.7; Ms = 0.4
Repeat accuracy	≤ 2 % of full scale
Temperature drift	≤ ± 10 %
Hysteresis	1...10 %
Ambient temperature	-25...+70 °C
Output function	4-wire, NAMUR
Valve control	Exi (max. 45 V)
Switching frequency	0.05 kHz
Voltage	Nom. 8.2 VDC
Non-actuated current consumption	≥ 2.1 mA
Actuated current consumption	≤ 1.2 mA
Approval acc. to	KEMA 02 ATEX 1090X
Design	Dual sensor for valve monitoring, DSC26
Dimensions	28 x 42 x 26 mm
Housing material	Plastic, PP
Active area material	Plastic, PP
Electrical connection	Connector, M12 x 1
Vibration resistance	55 Hz (1 mm)
Shock resistance	30 g (11 ms)
Protection class	IP67
MTTF	6198 years acc. to SN 29500 (Ed. 99) 40 °C
Packaging unit	1
Switching state	2 × LEDs, Yellow/Red

**Inductive sensor
For rotary actuators
NI4-DSC26-2Y1X2-H1140**



**Inductive sensor
For rotary actuators
NI4-DSC26-2Y1X2-H1140**

Accessories

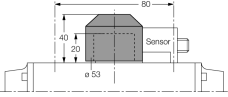
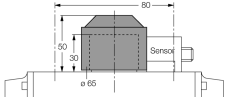
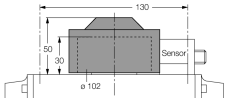
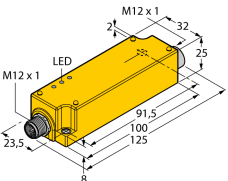
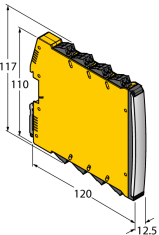
Type code	Ident-No.	Description	
BTS-DSC26-EB1	6900222	Actuation kit (puck) for dual sensors; end position damped; hole pattern on flange surface 80 x 30 mm and 130 x 30mm; connection shaft (shaft extension) height 20 mm / Ø max. 35 mm	
BTS-DSC26-EB2	6900223	Actuation kit (puck) for dual sensors; end position damped; hole pattern on flange surface 80 x 30 mm and 130 x 30mm; connection shaft (shaft extension) height 30 mm / Ø max. 50 mm	
BTS-DSC26-EB3	6900224	Actuation kit (puck) for dual sensors; end position damped; hole pattern on flange surface 30 x 130 mm; connection shaft (shaft extension) height 30 mm / Ø max. 85 mm	
IMC-DI-22EX-PNO/24VDC	7560003	2-channel isolating switching amplifier with M12x1 males, for peripheral use, IP67, zones 2/22, input circuits II(1) Ex ia, PNP transistor output NO	
IMX12-DI01-2S-2T-0/24VDC	7580020	Isolating switching amplifier, 2-channel; SIL2 acc. to IEC 61508; Ex-proof version; 2 transistor outputs; input Namur signal; ON/OFF switchable monitoring of wire-break and short-circuit; toggle between NO/NC mode; signal doubling; removable screw terminals; 12.5 mm wide; 24 VDC power supply	

**Inductive sensor
For rotary actuators
NI4-DSC26-2Y1X2-H1140**



Wiring accessories

Type code	Ident-No.	Description	
RKC4.441T-2/TEB	6628444	Connection cable, female M12, straight, 4-pin, cable length: 2 m, sheath material: PVC, black; cULus approval; other cable lengths and qualities available, see www.turck.com	<p>The diagram shows a side view of the connection cable. On the left is an M12 female connector with a diameter of 15 mm and a length of 14 mm. The distance from the start of the connector to the beginning of the cable jacket is 11.5 mm. The total length of the connector assembly is 42 mm. The cable jacket has a length of 50 mm, and the total length of the cable is denoted as L.</p>

Inductive sensor

For rotary actuators

NI4-DSC26-2Y1X2-H1140

TURCK
works

Industrial
Automation

Operating manual

Intended use

This device fulfills the directive 2014/34/EC and is suited for use in explosion hazardous areas according to EN 60079-0:2012 + A11 and EN 60079-11:2012.

Further it is suited for use in safety-related systems, including SIL2 as per IEC 61508.

In order to ensure correct operation to the intended purpose it is required to observe the national regulations and directives.

For use in explosion hazardous areas conform to classification

II 2 G and II 1 D (Group II, Category 2 G, electrical equipment for gaseous atmospheres and category 1 D, electrical equipment for dust atmospheres).

Marking (see device or technical data sheet)

⊕ II 2 G and Ex ia IIC T6 Gb and ⊕ II 1 D Ex ia IIIC T95 °C Da acc. to EN 60079-0, -11

Local admissible ambient temperature

-25...+70 °C

Installation/Commissioning

These devices may only be installed, connected and operated by trained and qualified staff. Qualified staff must have knowledge of protection classes, directives and regulations concerning electrical equipment designed for use in explosion hazardous areas.

Please verify that the classification and the marking on the device comply with the actual application conditions.

This device is only suited for connection to approved Exi circuits according to EN 60079-0 and EN 60079-11. Please observe the maximum admissible electrical values.

After connection to other circuits the sensor may no longer be used in Exi installations. When interconnected to (associated) electrical equipment, it is required to perform the "Proof of intrinsic safety" (EN60079-14).

Attention! When used in safety systems, all content of the security manual must be observed.

Installation and mounting instructions

Avoid static charging of cables and plastic devices. Please only clean the device with a damp cloth. Do not install the device in a dust flow and avoid build-up of dust deposits on the device.

If the devices and the cable could be subject to mechanical damage, they must be protected accordingly. They must also be shielded against strong electro-magnetic fields.

The pin configuration and the electrical specifications can be taken from the device marking or the technical data sheet.

In order to avoid contamination of the device, please remove possible blanking plugs of the cable glands or connectors only shortly before inserting the cable or opening the cable socket.

Service/Maintenance

Repairs are not possible. The approval expires if the device is repaired or modified by a person other than the manufacturer. The most important data from the approval are listed.